

Free Spirit

Gift Wrap Quilt

Featuring Silent Night by Cori Dantini

Techniques: Fussy Cutting, Pieced

Skill Level: Intermediate

Finished Size:

78¹/₂" x 78¹/₂" (1.99m x 1.99m)

Finished Block Size:

15" x 15" (38.10cm x 38.10cm)

Project designed by: Stacey Day

All possible care has been taken to ensure the accuracy of this pattern. We are not responsible for printing errors or the manner in which individual work varies. Please read the instructions carefully before starting this project. If kitting, it is recommended a sample is made to confirm accuracy.

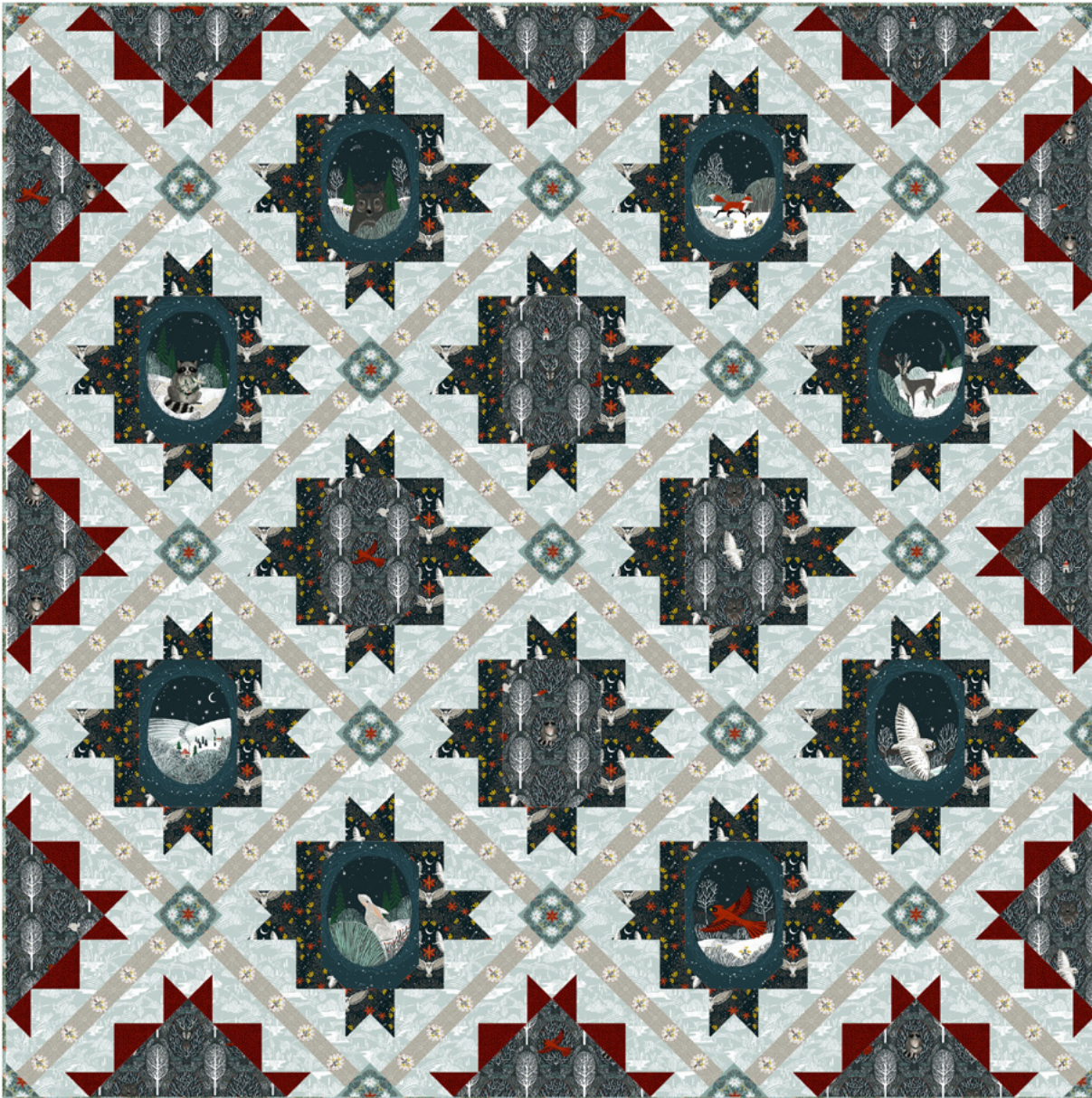

FABRIC REQUIREMENTS (Tech edited by: Alison M. Schmidt)

	Design	Color	Item ID	Yardage
A	Silent Night	Tile	PWCD173.XTILE	⅔ yard (0.61m)
B	Silent Scapes	Ice Blue	PWCD174.XICEBLUE	¾ yards (2.97m)
C	Woodland Friends	Navy	PWCD175.XNAVY	1⅝ yards (1.49m)
D	Soft Floral	Taupe	PWCD176.XTAUPE	1¾ yards (1.60m)
E	Flowers in the Thicket	Teal	PWCD177.XTEAL	⅝ yard (0.57m)
F	Branch Work	Multi	PWCD178.XMULTI*	¾ yard (0.69m)
G	Night Dreams	Midnight	PWCD179.XMIDNIGHT	1⅓ yards (1.22m)
H	Berry Dotty	Berry	PWCD180.XBERRY	½ yard (0.46m)

* includes binding

Backing (Purchased Separately)

44" (1.12m) wide

Silent Scapes Ice Blue PWCD174.XICEBLUE 5 yards (4.57m)

OR

108" (2.74m) wide

2⅝ yard (2.40m)

Swatches

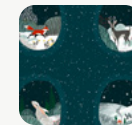

A



B

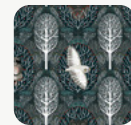

C

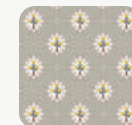

D



E

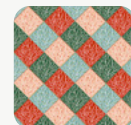

F

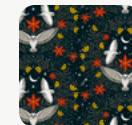

G



H



44"

ADDITIONAL REQUIREMENTS

- 100% Cotton Thread
- 87" x 87" (2.21m x 2.21m) batting
- **Optional:** Starch/starch alternative

CUTTING

WOF = Width of Fabric

HST = Half-square Triangle

QST = Quarter-square Triangle

Note: Press, starch, and allow fabrics to dry before cutting. Handle triangles gently to avoid stretching the bias edges.

From Fabric A, fussy cut:

(8) 7 $\frac{5}{8}$ " x 11 $\frac{1}{8}$ ", centered on the motifs

Fabric A Fussy Cutting Diagram



From Fabric B, cut:

- (6) 6¼" x WOF; subcut
 - (36) 6¼" x 6¼", then cut in half on both diagonals into
 - (144) QSTs
- (2) 3¾" x WOF; subcut
 - (12) 3¾" x 3¾", then cut in half on one diagonal into
 - (24) HSTs
- (5) 3" x WOF; subcut
 - (60) 3" x 3"
- (36) 1½" x WOF; subcut
 - (72) 1½" x 15½" for sashing

From Fabric C, cut:

- (4) 7⅝" x 11⅛", fussy cut centered on the motifs shown or your preferred motifs
- (3) 15½" x 15½"

Fabric C Fussy Cutting Diagram

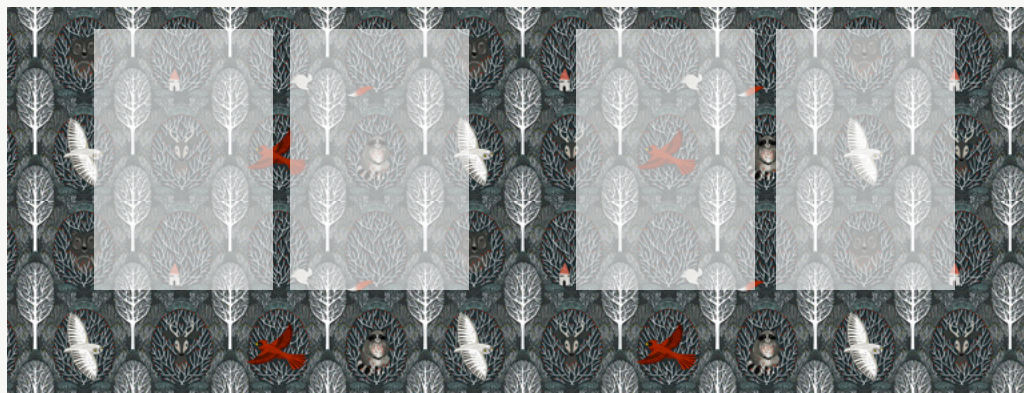

From Fabric D, fussy cut:

(18) 2" x WOF, centered on the motifs, then subcut

(36) 2" x 15½", so that the short ends are on the background print

Fabric D Fussy Cutting Diagram

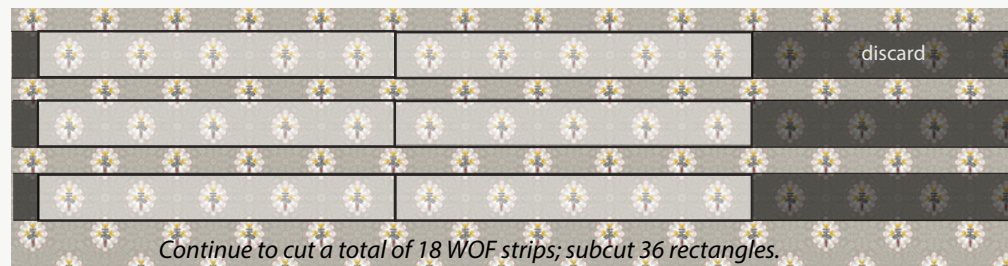

From Fabric E, fussy cut:

(13) 4" x 4" bias squares, centered on a white and red floral medallion

(2) 3¾" x 3¾", centered on a white and red floral medallion, then cut in half on one diagonal into (4) HSTs

(2) 6¼" x 6¼", centered on a small red flower, then cut in half on both diagonals into (8) QSTs

Fabric E Fussy Cutting Diagram

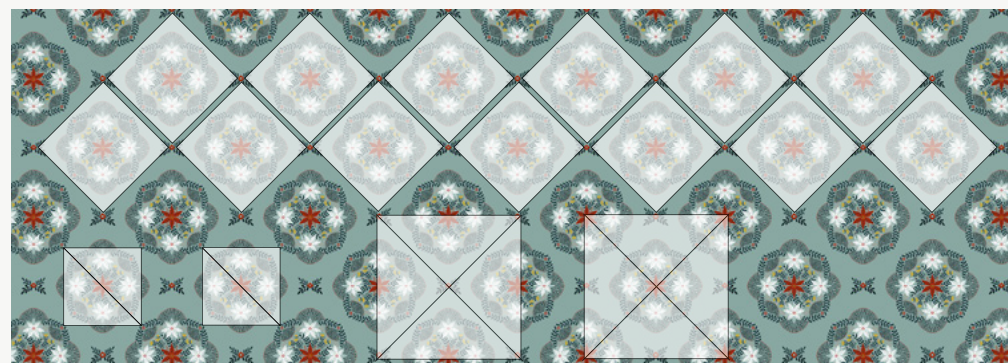

From Fabric F, cut:

(9) 2½" x WOF for binding

From Fabric G, cut:

(2) 6¼" x WOF; subcut

(12) 6¼" x 6¼", then cut in half on both diagonals into
(48) QSTs

(2) 5⅞" x WOF; subcut

(12) 5⅞" x 5⅞", then cut in half on one diagonal into
(24) HSTs

(6) 3⅜" x WOF; subcut

(60) 3⅜" x 3⅜", then cut in half on one diagonal into
(120) HSTs

From Fabric H, cut:

(1) 6¼" x WOF; subcut

(6) 6¼" x 6¼", then cut in half on both diagonals into
(24) QSTs

(3) 3⅜" x WOF; subcut

(24) 3⅜" x 3⅜", then cut in half on one diagonal into
(48) HSTs

INSTRUCTIONS

All seam allowances are ¼". Press following the arrows in the diagrams or as directed.

Block Construction

1 Fold the fussy-cut **Fabric A** and **C** 7⅝" x 11⅞" rectangles in half lengthwise and crease to mark the centers. Open, then fold in half widthwise and crease to mark the centers.

Fold all the **Fabric G** 5⅞" triangles and (24) **Fabric G** 3⅜" triangles in half through the long side and crease to mark the center.

Fig. 1

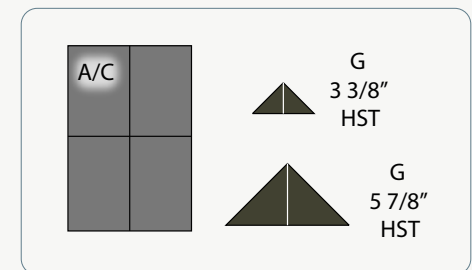

- 2** Pin and sew pairs of **Fabric G** $3\frac{3}{8}$ " triangles to the top and bottom of all the **Fabric A** and **C** $7\frac{5}{8}$ " x $11\frac{1}{8}$ " rectangles, matching center creases. Press towards **Fabric G**, then pin and sew a pair of **Fabric G** $5\frac{7}{8}$ " triangles to the left and right side of each unit, matching center creases. Press towards **Fabric G**. Trim and square to $10\frac{1}{2}$ " x $10\frac{1}{2}$ " as shown to complete (12) Unit A.

Fig. 2

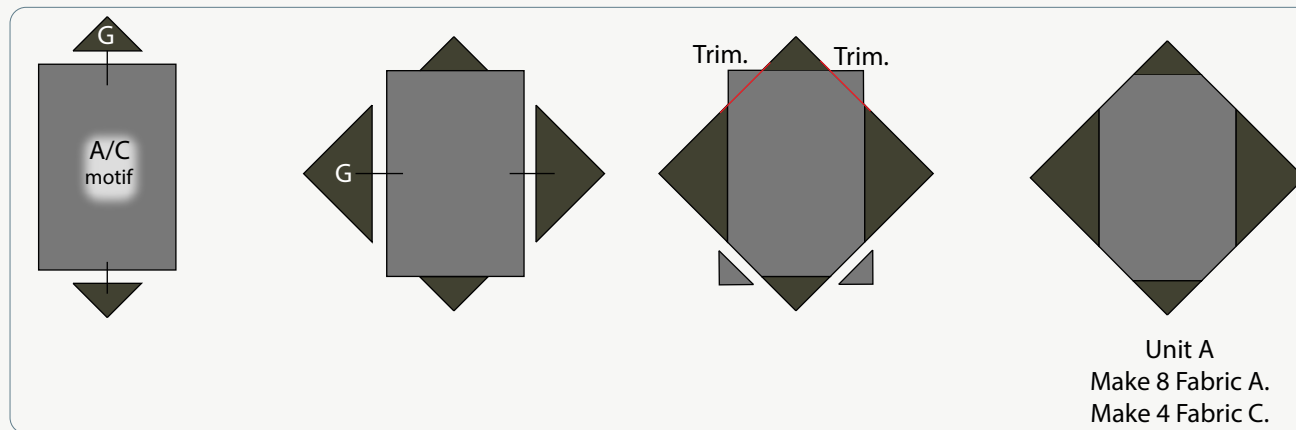

- 3** Arrange (2) **Fabric B** and (1) **Fabric G** $6\frac{1}{4}$ " QSTs, and (2) **Fabric G** $3\frac{3}{8}$ " HSTs together in a row as shown. Sew together, offsetting the triangle points to ensure the top and bottom of the row will form a straight line when sewn and pressed. Make (48) total of Unit B. Set (24) aside. Sew a pair of **Fabric B** 3" x 3" squares to opposite short ends of the (24) remaining units to complete Unit C.

Fig. 3a

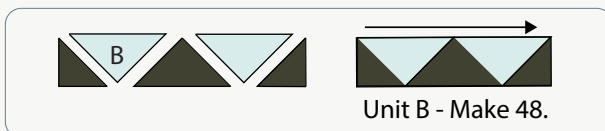
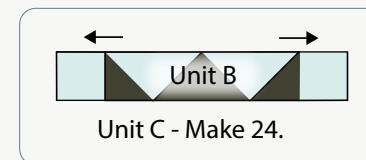

Fig. 3b



- 4 Arrange (2) **Fabric B** and (1) **Fabric H** $6\frac{1}{4}$ " QSTs, and (2) **Fabric H** $3\frac{3}{8}$ " HSTs together in a row as shown. Sew together, offsetting the triangle points to ensure the top and bottom of the row will form straight lines when sewn and pressed, to complete Unit B2. Make (24) total. Sew a **Fabric B** $3\frac{3}{8}$ " triangle to the right-hand end of (12) units as shown to complete Unit D. Sew a **Fabric B** $3\frac{3}{8}$ " triangle and a 3" x 3" square to opposite ends of the remaining (12) units as shown to complete Unit E.

Fig. 4a

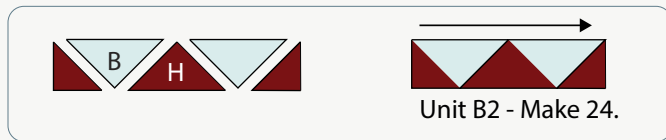
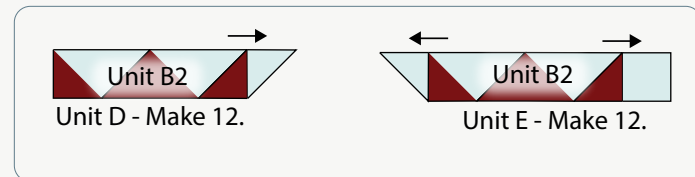
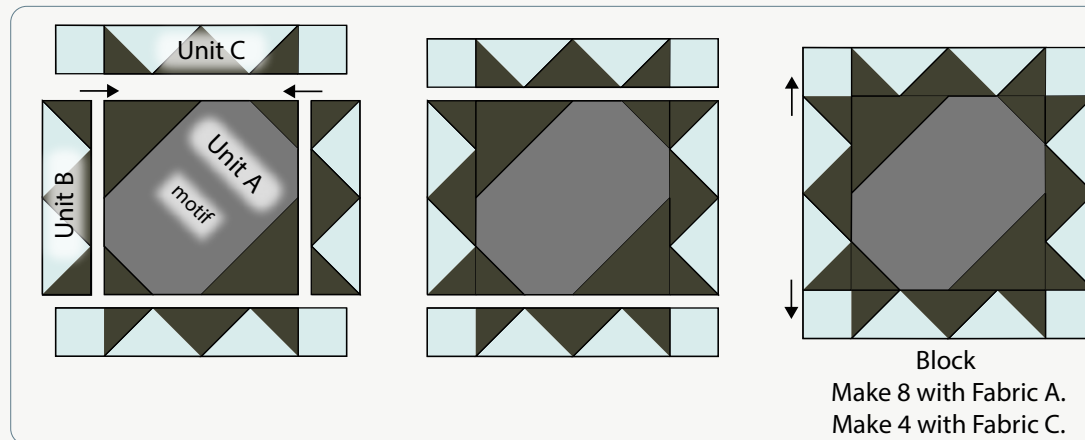

Fig. 4b



- 5 Arrange (1) Unit A and (2) each of Units B and C together in (3) rows as shown. Sew the center units together into a row, then add Unit C to the top and bottom to complete a Block ($15\frac{1}{2}$ " x $15\frac{1}{2}$ "). Make (12) Blocks total, (8) with **Fabric A** and (4) with **Fabric C**.

Fig. 5



- 6 With the fabric print oriented right-reading, cut all the **Fabric C** 15½" squares on both diagonals into (12) triangles, and label each as top, bottom, left, or right as shown according to the direction of the motif in the triangles.

Arrange (1) **Fabric C** 15½" triangle, (1) Unit D and (1) Unit E as shown, then sew the units to adjacent sides of the triangle to make a Setting Block. Make (12) total (3 each top, bottom, left, and right)

Fig. 6a

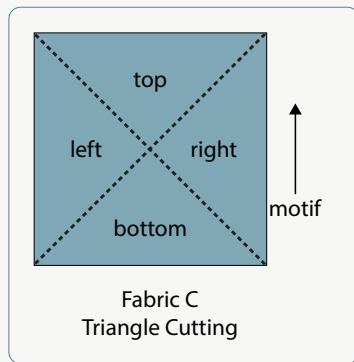
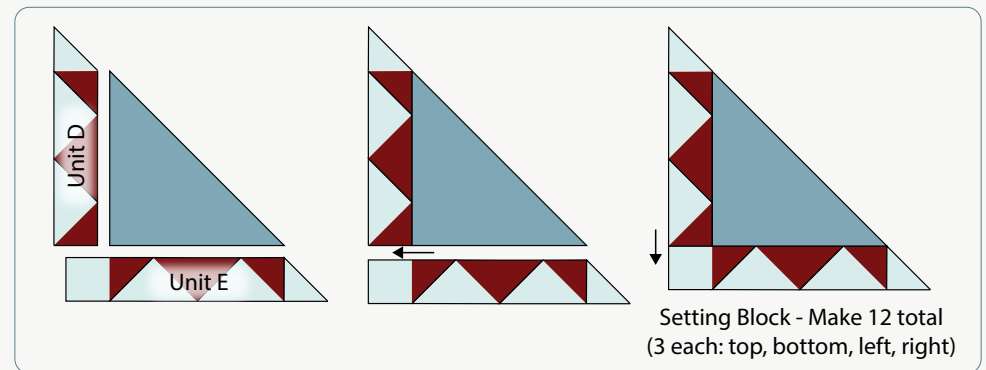
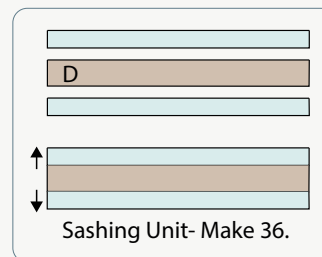

Fig. 6b



- 7 Sew (2) **Fabric B** 1½" x 15½" strips and (1) **Fabric D** 2" x 15½" strip together as shown to make a Sashing Unit. Make (36). Set (18) aside.

Fig. 7



- 8 Arrange the remaining Sashing Units, **Fabric E** 4" x 4" bias squares, **Fabric E** 6 1/4" QSTs and **Fabric E** 3 3/8" HSTs together in rows as shown. Sew together to make 3 different Sashing Rows in the quantities listed.

Fig. 8

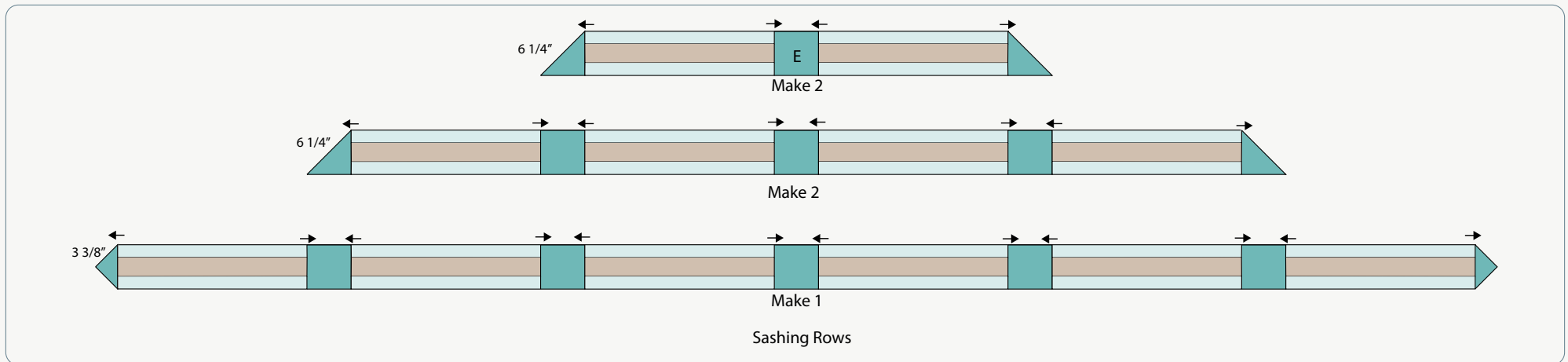

QUILT TOP ASSEMBLY

- 9 Arrange the Blocks, Setting Blocks, and Sashing Units together into diagonal rows, referring to the **Quilt Layout** diagram (p. 12) and quilt image (p.1) for placement of each block, and making sure all the fussy-cut centers are right-reading.
- 10 Sew the blocks and Sashing Units together into rows. Press towards the sashing strips.
- 11 Sew the block rows together with a Sashing Row between them. Sew the (2) remaining **Fabric E** 3 3/8" triangles to the open corners to finish the quilt top.

FINISHING

- 12** Sew together the 2½"-wide **Fabric F** binding strips end to end. Press the seams open. Press the binding strip in half wrong sides together.
- 13** Layer the backing (wrong side up), batting, and quilt top (right side up). Baste the layers together and quilt as desired. Trim excess batting and backing even with the quilt top after quilting is completed.
- 14** Leaving an 8" tail of binding, sew binding to top of quilt through all layers matching all raw edges. Miter corners. Stop approximately 12" from where you started. Lay both loose ends of binding flat along quilt edge. Where these two loose ends meet, fold them back on themselves and press to form a crease. Using this crease as your stitching line, sew the two open ends of the binding together right sides together. Trim seam to ¼" and press open. Finish sewing binding to quilt.
- 15** Turn the binding to the back of the quilt and hand stitch in place.

Quilt Layout

